

# Circuit-Breaker Model for Over-Current Protection Simulation of DC Distribution Systems

T. ROBBINS

TELSTRA RESEARCH LABORATORIES  
BOX 249 ROSEBANK MDC, CLAYTON VICTORIA 3168, AUSTRALIA  
Email: t.robbins@trl.oz.au

## Abstract

This paper describes an electrical model of a thermal-magnetic circuit-breaker that can accurately simulate characteristic behaviour over a wide range of over-currents, including operation in the magnetic region. The model has been validated against measured waveforms from both a high-current DC test facility and a distributed power system rack. The circuit-breaker model can be coupled with other distribution component models to simulate the protection performance in telecommunications DC distribution systems.

## 1. Introduction

The design and analysis of over-current protection for telecommunication DC power systems can be greatly assisted by the use of a computer-aided simulation tool. However, a simulation is only as accurate as the component models and element values used to represent the real world. This paper reports on the development of a circuit-breaker model that can accurately represent circuit-breaker behaviour over a wide range of over-currents.

The performance of protection, distribution and storage devices significantly affects both the reliability and safety of the DC power system. Voltage excursions caused by an over-current instance can cause electronic equipment to malfunction due to over-voltage, and disrupt service due to under-voltage. Poor discrimination between protection devices can cause upstream device operation, resulting in major interruption to service.

The rapid advancement of both computing power and analogue circuit simulation programs derived from SPICE software provides a relatively user-friendly environment for over-current protection design and analysis. This is advantageous as telecommunications power distribution systems are often large and complex, and developing an equivalent circuit model for a power system is not a trivial task.

The circuit-breaker model described in this paper implements the enhanced modelling functions available with PSpice's *Analog Behavioural Modelling* to include circuit-breaker current, time and arcing dependent characteristics. This model complements and extends

previously published modelling work [1-2] by Telstra Research Laboratories on other power system components.

## 2. Circuit-Breaker Characteristic Operation

A typical thermal-magnetic circuit-breaker operates (trips) in two distinct modes; the thermal mode occurs for device currents from 1 up to about 10-15 times the rated setting current, and the magnetic mode occurs for all current levels above the thermal operating region. Characteristic current-time curves for the device operating in the thermal region can be approximated by an equation where  $i^n t$  equals a constant, whereas in the magnetic region the operating time (typically <20ms) is not well defined in device data curves and specifications, as test circuits are based on rectified AC power sources which have typical rise times exceeding a few milliseconds.

The circuit-breaker model presented in this paper has been developed for a 125A moulded device (10kA fault rating), which is commonly used to protect individual battery strings within Telstra's distributed power supplies.

For device operation in the thermal region, the characteristic  $i^n t$  form of the current-time curve can be obtained from the device specification curve as shown in Figure 1. A value of  $n = 3.5$  gives an adequate fit over the range of currents within the thermal operating region.

For device operation in the magnetic region, characteristic current-arc voltage-time behaviour has been observed for the circuit-breakers operating in a high-current DC test facility over a range of current levels and circuit time constants. At the start of such a fault instance, the current passing through the closed circuit-breaker contacts increases to a level where magnetic activation forces the contacts to open. As the contacts start to open an arc is developed which is inherently unstable and a complex voltage-current characteristic occurs as the arc progresses through to extinction.

For the 125A circuit-breaker operating in the magnetic region, the contacts are forced open when the current

level typically rises above 2-4kA. Circuit-breaker operation was measured over a range of circuit conditions, such as:

- fast rates of current rise exceeding 10kA/ms, which resulted in short pre-arcing times of about 0.15-0.2ms (eg. results from a test circuit with 5.4kA prospective current and 0.26ms time constant are shown in Figure 2).
- high prospective current levels exceeding 10kA, which result in pre-arcing times around 0.9ms for circuit time constants of about 1.2ms, as shown in Figure 3.

It should be noted that special oscilloscope probing and current shunt techniques are required to record clean waveforms in the high transient noise environment that occurs in a high current test facility.

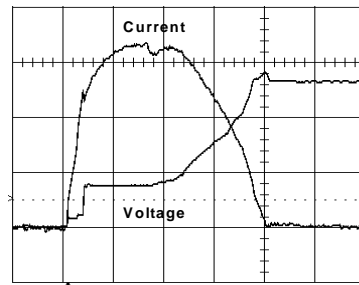

**Figure 2.** Measured current and voltage waveforms for a 125A circuit-breaker operating in 54VDC test circuit with 5.2kA prospective current and 0.25ms prospective time constant; 1kA/div current, 20V/div voltage and 0.5ms/div.

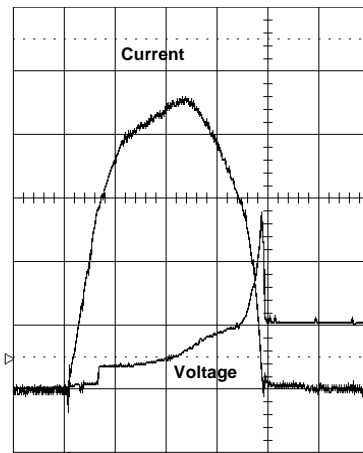

**Figure 3.** Measured current and voltage waveforms for a 125A circuit-breaker operating in 54VDC test circuit with about 12kA prospective current and about 1ms prospective time constant; 1kA/div current, 50V/div voltage and 0.5ms/div.

## D125

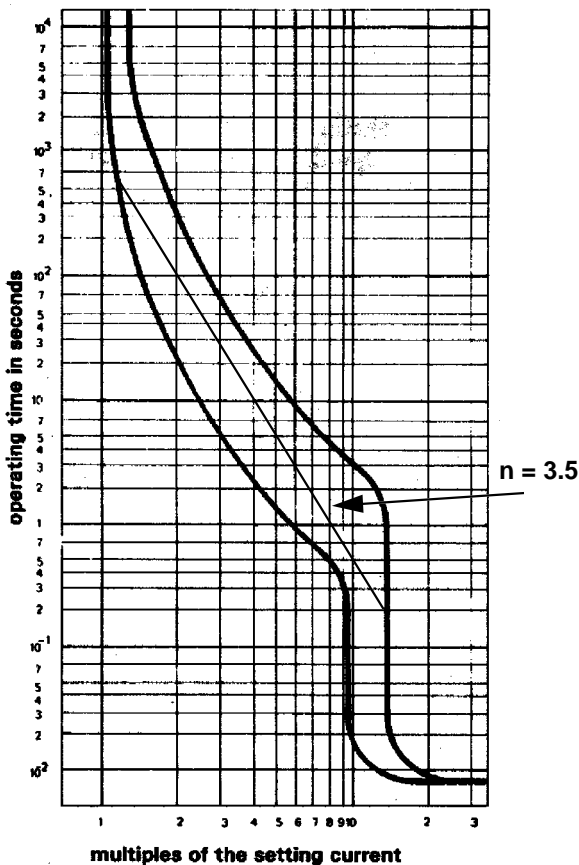
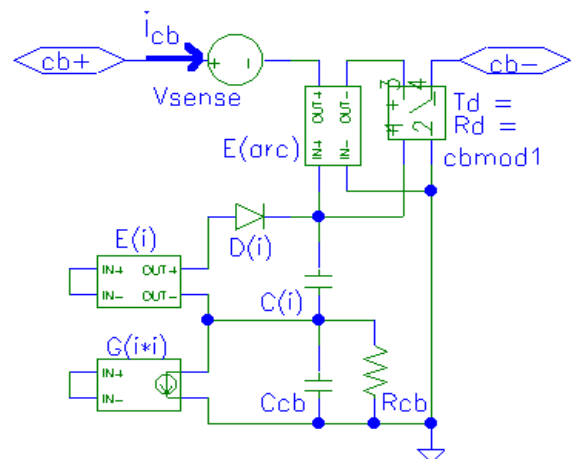

Figure 1. 125A circuit-breaker current-time operating boundary curves (courtesy of GEC ALSTHOM AUSTRALIA).



**Figure 4.** Circuit-breaker model.

### 3. Circuit-breaker Model

The circuit-breaker model is shown in Figure 4. Current  $i_{cb}$  through the circuit-breaker flows between I/O pins **cb+** and **cb-**, passing through the voltage source **Vsense**, voltage-controlled voltage source **E(arc)** and voltage-controlled switch **cbmod1**. **Vsense** acts as an ideal current meter.

To model the thermal characteristic of the circuit-breaker, the current  $i_{cb}$  measured by **Vsense** is passed to the current-controlled current source **G(i\*i)**, which outputs a current equal to  $i_{cb}$  raised to the power **n**, whenever  $i_{cb}$  exceeds the rated current  $i_r$  of the circuit-breaker. The change in voltage developed across **Ccb** is then,

$$\Delta V_{Ccb} = \int_{t_1}^{t_2} G(i*i) dt$$

$$\text{where, } G(i*i) = (i_{cb})^n, \text{ when } i_{cb} > i_r$$

$$= 0, \text{ when } i_{cb} \leq i_r$$

By making the capacitor **Ccb** value equal to the pre-arcing  $i^n t$  of the circuit-breaker, in  $A^2s$ , the voltage developed across **Ccb** at the end of the pre-arcing time is normalised to 1V. The thermal loss of the circuit-breaker is modelled by the resistor **Rcb**, which discharges the voltage across **Ccb**.

To model the magnetic characteristic of the circuit-breaker observed in Figures 2 and 3, a voltage source **E(i)**, which is controlled by the current  $i_{cb}$ , outputs a voltage that linearly increases from 0 when the current level exceeds  $i_{m1}$ , rising to a maximum of 1V when the current level reaches  $i_{m2}$ . The diode **D(i)** and capacitor **C(i)** provide a peak hold function to allow the simulation to proceed in a latching action.

The arc voltage initially generated as the contacts break, **Va**, is modelled by a voltage sourced from **E(arc)**. The voltage-controlled switch **cbmod1** models the DC resistance of the circuit-breaker with closed contacts **Rd**, the resistance increase as the arc extinguishes, and the one-way action of the opening contacts. The input to **E(arc)** and **cbmod1** is the voltage developed across both **Ccb** and **C(i)**.

The switch **cbmod1** is a digital subcircuit which switches off when its controlling input voltage exceeds 1V. The change in switch resistance during the off transition is controlled by a time delay factor **Td** and a resistance factor **Rd**. Three series connected resistance's in **cbmod1** model the circuit-breaker arc resistance increase.

Model parameter values are given in Table 1, based on typical measured characteristics of a 125A circuit-breaker.

<b>Va</b>	initial arc voltage	13V
<b>i<sub>r</sub></b>	rated operate current	125 A
<b>n</b>	current-time thermal curve fit	3.5
<b>Ccb</b>	$i^n t$ value @ $i=10i_r$	6.9 E10 $A^n \cdot sec$
<b>i<sub>m1</sub></b>	current level to start magnetic operation	2,000 A
<b>i<sub>m2</sub></b>	current level to end magnetic operation	2,500 A
<b>Rd</b>	DC resistance with contacts closed	0.8 mΩ

Table 1. 125A circuit-breaker model parameters.

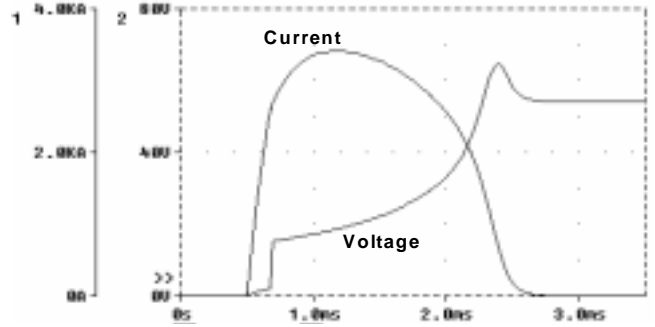

Figure 5. Simulated current and voltage waveforms for a 125A circuit-breaker operating in 54VDC circuit with 5.2kA prospective current and 0.25ms prospective time constant.

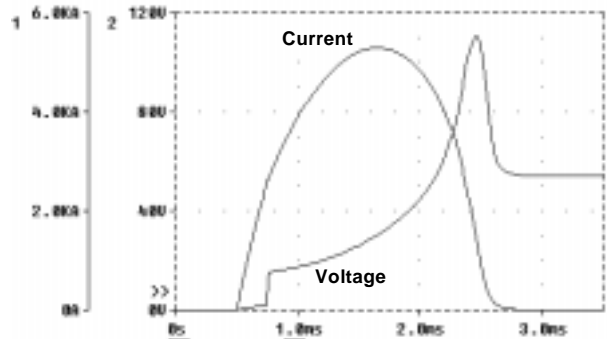
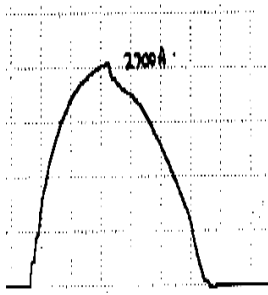
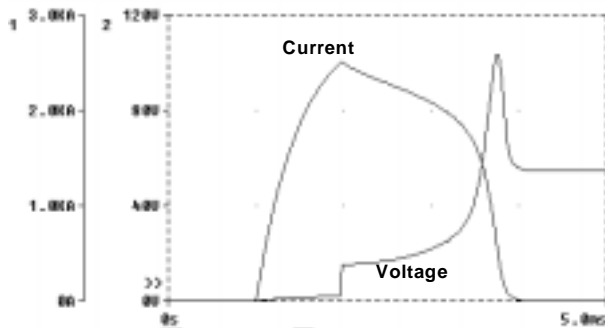

Figure 6. Simulated current and voltage waveforms for a 125A circuit-breaker operating in 54VDC circuit with 12kA prospective current and 1ms prospective time constant.



**Figure 7.** Measured current waveform for a 125A circuit-breaker when protecting a battery string within one of Telstra's distributed power supplies. 667A/div and 0.5ms/div.



**Figure 8.** Simulated current and voltage waveforms for a 125A circuit-breaker when protecting a battery string within one of Telstra's distributed power supplies.

#### 4. Model Validation

Measured voltage and current waveforms of a 125A circuit-breaker operating in both a DC high-current test facility and a distributed power system rack were used to validate the model when operating in the magnetic region. Operation in the thermal region is not shown, as this mode is typically of secondary importance when investigating over-current protection in telecommunications power systems.

Figures 5 and 6 show simulated waveforms of the circuit-breaker model operating in circuits with equivalent characteristics to the test circuits used to obtain the measured waveforms shown in Figures 2 and 3 respectively.

Simulated results show quite good agreement with measured results considering the complex physical arcing process that takes place during circuit-breaker operation. The major area of discrepancy is the over-voltage transient generated as the arc extinguishes. It should be noted that minor waveform variations have been observed with repeated tests under the same test conditions.

The circuit-breaker model has assisted Telstra's power system designers to analyse the operation of a 125A circuit-breaker operating in a Telstra distributed power system battery rack. The measured current waveform of a circuit-breaker interrupting a short circuit from the 48V battery string negative (active) output terminal to the rack frame is shown in Figure 7. No voltage waveforms were taken in this test. Figure 8 shows simulated waveforms of the circuit-breaker model operating in a circuit with equivalent characteristics to that used to obtain the measured waveform shown in Figure 7. Again, quite good agreement is obtained between the simulated and measured current waveform.

#### 5. Conclusion

In summary, this paper describes a new circuit-breaker model that accurately represents circuit-breaker behaviour in DC distribution systems over a wide range of over-currents. The circuit-breaker model can be coupled with other distribution component models [1-2] to simulate the protection performance in telecommunications DC distribution systems. The development of this circuit-breaker model, and other previously published modelling work, has provided Telstra power system designers with a useful design and analysis tool.

#### Acknowledgements

The permission of the Director of Research, Telstra Research Laboratories, to publish the above paper is hereby acknowledged. The author would like to thank D. Salter from Telstra's Power & Network Standards group for conducting measurements on the distributed power system rack. The author would also like to thank G. McCready from GEC ALSTHOM AUSTRALIA for supplying circuit-breaker samples for testing and permission to reproduce Figure 1.

#### References

- [1] T.P.Robbins, "Fuse model for over-current protection simulation of DC distribution systems", In Proceedings of the Conference INTELEC, 1993, pp.336-340.
- [2] T.P.Robbins, "Battery model for over-current protection simulation of DC distribution systems", In Proceedings of the Conference INTELEC, 1994, pp.307-314.