

1. Summary

AWA PA1003 25W valve amplifier. S.N. AL4518. Nov 2019

Three input channel PA amplifier. 7027A cathode biased PP stage – screen at B+ - cathode bias from 2x 12AX7 heaters in series.

1.5A fuse. Doubler on 250V secondary using 1N3195's; 90uF 450V caps, then 0.5A fuse for ~200V HT to PP stage. 6V3 with 47R-GND-47R humdinger. Socket for Radio aerial/earth. Bass Normal/Cut switch. 10 section terminal block*. [MIC] Volume pot. Input socket. Phono [Radio] Vol pot. Phono [Radio] switch. Phono-[Radio] Tone pot. Extension switch*. Speaker vol pot*. Mains On switch. Monitor socket*. Front panel VU meter* and two 4-step switches*.

Output Transformer	Type No. 2426 25W nominal 2000Ω PP 7 output winding sections 0,24R,40R,60R,120R,200R,300R,400R. Secondary turns ratios: 0-24-31-39-55-71-87-100%. No interleaving.
Power Transformer	52424A CC5 (Bell ends look like from Ferguson). 250V @ ~200mA (RD,RD); 6V3 ~3A (BLK,BLK); 250-230-10-0V (YEL,OR,GRY,BLU) Upright with steel bell-ends. 100x80mm footprint. 115mm high.
POTs	Aerostat.
Caps	Ducon electros 483; Ducon poly 335; 376 UCC EPB 28 1164 1864, PHT 175 265 and mustard 051H 095H;
Resistors	IRH 61 15 Z. 65 7
Valves	7027A x2 RCA USA AQ 12AX7 2x Radiotron Australia JG 10, UM 22
Speaker	AWA 6.40A/15 50 230 DE5
Meter *	Kyoritsu VR-3P VU -20 to +3

Good general condition. Original condition, including valves, but vintage modified for VU meter and input switches. Some added internal wiring poorly located. Slight change to input heater wiring – cap to cathodes, 1k5 across series heaters. No bleed/balancing resistors on B+. Fuse in OPT feed. Mains switch contact poor. Modified Monitor parts and wiring and poor wiper on pot. All coupling caps leaky. One ss diode with some leakage.

2. Modifications

- Swapped contact on Mains switch.
- PT orange tap isolated and yellow tap taken to terminal strip. 275Vac MOV added across primary.
- Replaced humdinger with 82+82 0.4W.
- Replaced ss diodes with paralleled UF4007.
- Added secondary HT CT 5x20mm fuse.
- Removed rear panel Ant socket and replaced with DB9 monitor connector, and added 100:1 divider bleeds on VS1 and VS2, and connection to top of heater NTC. Caution that common cathode voltage should not exceed 30Vdc FSD for meter assembly (damage above 42Vdc).
- Removed side input jack and socket. Isolated front panel input socket.
- Replaced coupling caps. Preamp stages with 10nF and output stage with 22nF, to restrict low frequency bandwidth. Inserted 10k grid stoppers for output stage.

- Reconfigured OT for 11 ohm output, and added Speakon speaker socket (removed B+ 3AG rear panel fuse).
- Added LC filter stage to VS1 (and hence screen).
- Removed OT feedback to PI, and used F/B winding for internal speaker. Reconfigured speaker and monitor wiring.
- Removed radio socket and wiring.
- Replaced electrolytic caps.
- Disconnected front panel extension switch. Disconnected rear panel Bass Cut switch. Front panel Phono-MIC switch used as Bass cut switch.
- Added VU meter circuitry for peak hold and to display relative dBm (where 0dBm ~ 12W in to 16 ohm).
- Added 200D7 NTC in series with V1-V2 heater string as output stage common cathode bias resistor.



3. Measurements

Megger test 1kV on PT mains and HT secondary (>2G) and OT primary (>1G).

PT:

- Pri: BLU-YEL 12.1 ohm (YEL-OR 1.1 ohm; OR-GRY 10.4 ohm; GRY-BLU 0.4 ohm)
- Sec: RD-RD 9.2 ohm
- 237Vac mains on Gry-YEL: 157V HT unloaded; 6.77V heater unloaded, 6.58V heater loaded.

Voltage rail regulation.

Rail	238V 0.44A	
VS1	370V (430Vpk)	
VS2	248V (340Vpk)	
Cathode	24.1-V (65+69mA)	
NTC	4.3V	

12VAC 50Hz nominal applied to output transformer half-primary

Winding	Voltage rms	Turns ratio; Impedance for 5.0K pri; Spec level; Notes
Pri P-B+	11.39	
Sec: GRY to PUR	6.44	3.54; 400Ω; 400Ω; 1000T
Sec: GRY to BLK/WH	5.555	4.10; 297Ω; 300Ω; 863T
Sec: GRY to RED/WH	4.563	4.99; 201Ω; 200Ω; 709T
Sec: GRY to OR	3.533	6.45; 120Ω; 120Ω; 549T
Sec: GRY to BLK	2.492	9.14; 60Ω; 60Ω; 387T
Sec: GRY to GRN	2.022	11.27; 39Ω; 40Ω; 314T
Sec: GRY to YEL	1.481	15.38; 21Ω; 24Ω; 230T
Sec F/B	2.284	9.97; 50 Ω; 355T

Output transformer primary DC resistance: 96 + 101Ω

Four sections of windings each have about 16% of turns, but there is a minor turns difference between them (when their tap wires were separated and separately measured). The measured signal voltages (no load), DCR, and calculated signal currents for each winding section (when the 60-120Ω winding is driving 16.5V in to a resistive load) are:

- 24 to 60 ; 1.02V 615mΩ 1.380A
- 60 to 120 ; 1.05V 655mΩ 1.416A
- 120 to 200 ; 1.035V 685mΩ 1.392A
- 200 to 300 ; 0.992V 680mΩ 1.335A

Connecting those 4 winding sections in parallel provides an 11Ω nominal output that uses 48% of the secondary turns. At full rated output of 25W, the likely span in generated winding currents into a common resistive load is about 0.08A (or 6% of nominal).

Input stage signal gain $1.16/0.0204 = 57x$

2nd stage signal gain $1.45/0.011 = 132x$ (tone max) ; $1.1/0.011 = 100x$ (tone min)

Output sine clip in to 16Ω load at 17.4Vrms (19W), and 11.4Vrms in to 8Ω load (16W). Clipping nearly symmetrical. Cathode voltage rises from circa 24 to 28V, and NTC voltage increases a bit even though cathode currents increase 5-10mA. VS1 and VS2 sag only about 10V. VU meter reads about +0.5dB

Output noise (no input, pots min) 1mVrms

With tone switch (up), the tone pot only influences above 300Hz.

- Pot at min gives -3dB at 170Hz and 3kHz, and -16dB at 10kHz.
- Pot at mid gives -3dB at 150Hz and 3kHz, and -9dB at 10kHz.
- Pot at max gives -3dB at 170Hz and 8kHz.

With tone switch (up):

- Pot at min gives -3dB at 170Hz and 4.5kHz, and -12dB at 10kHz.
- Pot at mid gives -3dB at 400Hz and 9kHz, with 2dB hump at 3kHz.
- Pot at max gives -3dB at 700Hz and 8kHz, with broad hump at 3kHz.

VU Meter: FSD with 212uA. Resistance = $1.44\text{V}/0.000212 = 6\text{k}\Omega$.

VU meter response modified with series non-linear resistance from 3V6 zener string with resistors used to align with sinewave power level in dB. Output waveform half-wave rectified with high voltage germanium OA81, and 4u7 filter across meter. Measurement with $V_{dc}=V_{pk}$ applied.

VU +3dB reading at 29.1Vpk. Equivalent power level is 26.5W, or 44.2dBm,	ref +3.5dB
VU +2dB reading at 25.7Vpk. Equivalent power level is 20.6W, or 43.1dBm	ref +2.4dB
VU 0dB reading at 19.4Vpk. Equivalent power level is 11.8W, or 40.7dBm	ref 0dB
VU -1dB reading at 16.35Vpk. Equivalent power level is 8.4W, or 39.2dBm	ref -1.5dB
VU -3.1dB reading at 11.6Vpk. Equivalent power level is 4.2W, or 36.2dBm	ref -4.5dB
VU -5.9dB reading at 7.9Vpk. Equivalent power level is 2.0W, or 33dBm	ref -7.7dB
VU -16dB reading at 3.07Vpk. Equivalent power level is 0.3W, or 24.8dBm	ref -15.9dB

4. Design

4.1 Input 12AX7 microphone stages

Input 12AX7 stage, B+= 260V; Va=190V; Rk=2k2; Ia=0.47mA; RLdc=220k.

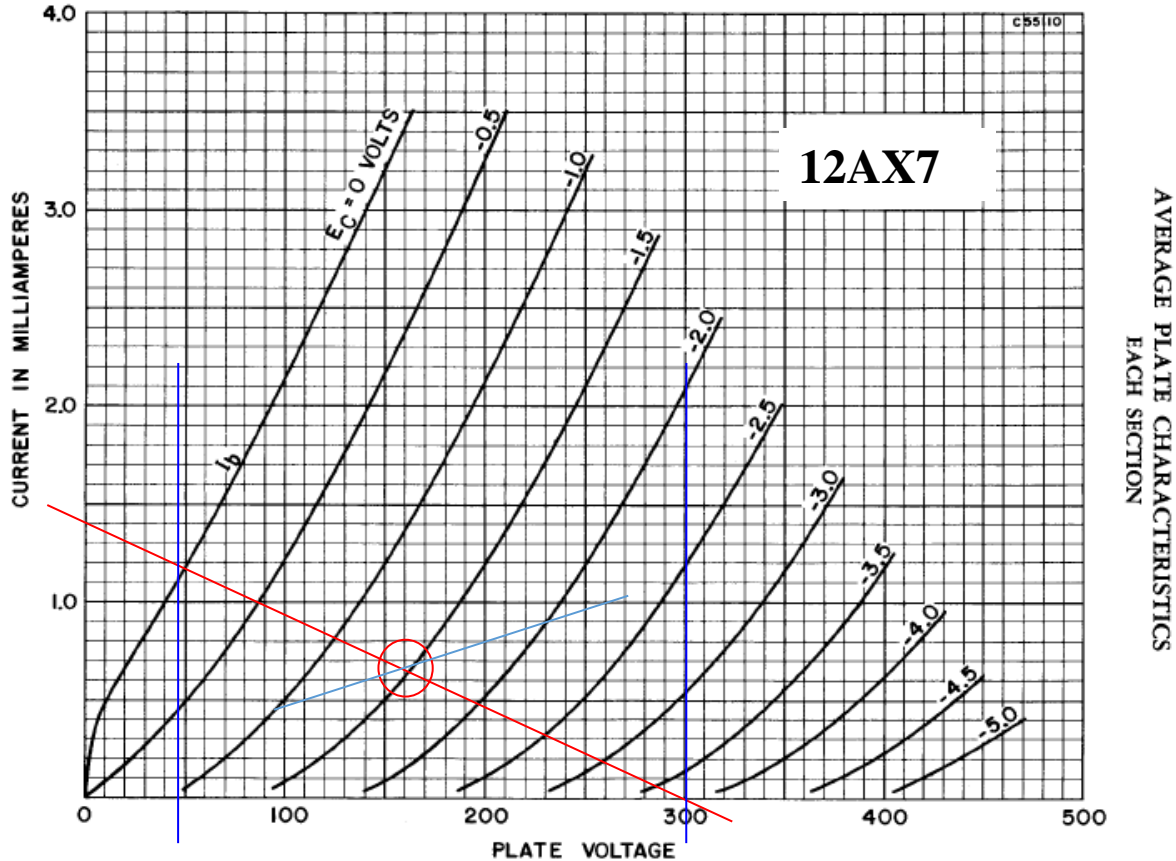

4.2 PP Output Stage

Original design for 7027A could have common cathode current up to 80+80mA, based on 150mA heater current and extra 10mA for 1k5. 7027A max dissipation is 35W, so with 28V cathode bias, and 395V B+, the max anode current is 95mA, so reasonable to operate at 85% max dissipation. Datasheet indicates 5k PP loading is appropriate for cathode bias with screen rail = B+.

Alternatives to 7027A are limited by max heater winding current rating, which is unknown, but is at least $2 \times 0.9 = 1.8A$. 0.9A heater options are 6L6GC and 7581A, where 6L6GC is 30W anode dissipation but has same class AB1 fixed bias 450V-350V output stage ratings as 7027A.

The max design output valve bias current allowed is dependent on the maximum recommended plate dissipation of $30 \times 0.8 = 24W$ for 6L6GC: $I_{bias(max)} = P_d / V_b = 24W / 370V = 65mA$. VS1 drop across OPT is $\sim 0.07 \times 100 = 7V$. Max diss with screen is 35W.

The heater string may need series or parallel padding resistors to get desired bias current for final setup of screen voltage. Parallel Zener can be used for constraining 12AX7 heater voltage to say +5% (26.5V). Effective cathode resistance is circa $26V / 0.15A = 175\Omega$.

Initial cold 12AX7 heaters cause turn-on stress of output stage valves from low bias voltage, as cold heater string resistance is about 26Ω compared to operating resistance of 175Ω , and so initial cathode bias is about 15%. The likely surge current through the cathodes is less than a typical application of heater voltage from a transformer secondary winding, so the 12AX7 heaters likely take longer to warm up. This could be alleviated by using an appropriate NTC due to its high cold resistance. NTC working current would be about 150mA, so NTC-200D7 (or MF72) has a max current rating of 0.2A (so 150mA is 75%) and a min hot resistance of circa 12Ω , with a cold resistance of 200Ω . Initially the output stage cathodes would be slightly cold biased, so the warm-up current available to the 12AX7 heaters is effectively current limited.

The NTC idles at 4.4V for 136mA (32Ω , 0.6W) with heater string at 20.8V and cathodes at 25.2V. To maintain the same bias voltage of $\sim 25V$, but increase heater voltage, a 1k2 in parallel with heaters draws 20mA more through NTC to lower its voltage to 3.4V, and a 6R9 is added in series with total.

If the 12AX7 are not fitted, or a heater circuit open-circuit fault occurs, then the output stage valve cathodes can float high and stress the heater-cathode interface, so a 150V Zener is connected from cathode to gnd for protection.

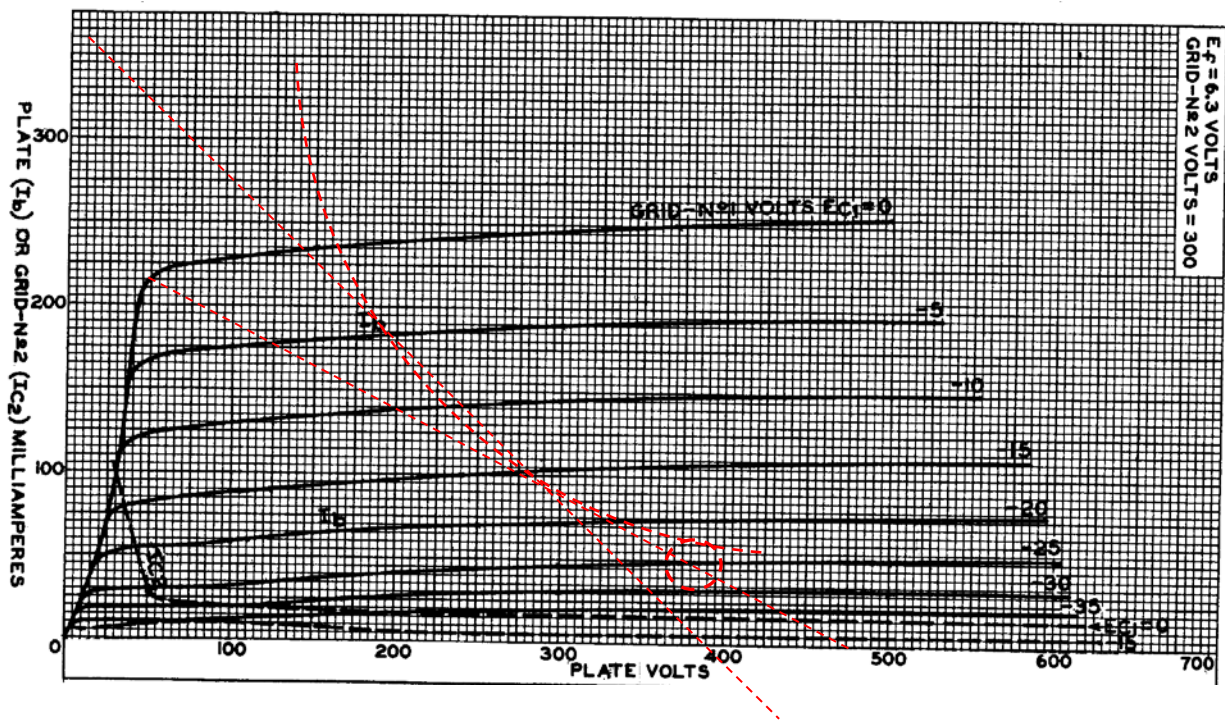

4.3 Powering

Mains fuse reduced from 1.5A to 1A, with about 0.4A at idle.

Doubler rectifier with 140mA hot load on 400V VS1. Max anticipated continuous VS1 load current about 160mA. Continuous fuse current about 570mA at idle when located in series with winding. IEC60127-2 630mA Time-delay fuse, as max continuous winding current shouldn't exceed 630mA for long durations. A bolted short load or short on the plate side of the OPT could cause a current level of 10x fuse rating, and fuse would blow in under 0.3 sec. A loss of bias on the output stage valves ($V_g=0V$) could cause a current level up to 5x fuse rating and fuse may need up to 2s to blow.

Simulate period in PSUD2	20ms	40ms	100ms	500ms	continuous
Simulated RMS current	2.9A	2.2A	1.6A	0.85A	0.63A
Multiplier (based on 0.63A fuse rating)	4.6	3.5	2.5	1.4	1
IEC60127-2 Time-delay min limit multiplier	10	~7	~4.8	~2.9	1

Capacitor ripple current about 400mA_{rms} max. Physically smaller 47uF 250V caps have low ripple current ratings (270mA Yageo SH; 390mA Samwha SG; 240mA Rubicon YXA), but can be well above 400mA. Frequency is 50Hz and ripple current multiplier may be down to x0.75. The DELTEC RM is large at 40x17mm and has 105C rating.

Diode continuous rms current at idle is 405mA, so use 2x UF4007 in parallel.

4.4 Output level indicator

The original VU meter was disconnected.

The VU meter was included in a half-wave rectified and filtered circuit, with a Zener-resistor based series resistance designed to provide a nominal dBm reading with 0dB mark at 12W in to 16ohm resistive load. 3V6 zeners were used to soften the current-voltage curve around their knee region.

4.5 Monitor Speaker

Monitor speaker is 15Ω and connected through 120Ω to 100Ω 2W WW front panel pot wiper, with return via a contact on the external monitor socket. The pot is connected across the 60Ω (BLK) to 120Ω (OR) taps, which is 11Ω nominal tapping. The original wiring appears to be modified.

The max pot current rating is $\sqrt{(2W/100\Omega)} = 140mA_{rms}$. The 50Ω feedback winding has a max prospective voltage of 35V_{rms}. The min loading of any pot/speaker configuration needs to exceed 250Ω 5W to keep pot current under 0.14A.

Modification:

- For simplicity, the feedback 50Ω winding was connected to the 100Ω pot through a 560Ω 2W series resistor, and the wiper connected to the external speaker socket, with a socket contact to connect the internal speaker. With pot at min, the 660Ω loading of the feedback winding could dissipate up to 0.6W.

4.6 Maintenance / setup

Female DB9 on the rear panel used to sense Common cathode, VS1/100, VS2/100, and NTC, with respect to 0V ground, and V3 and V4 cathodes wrt common cathode through 10R sense resistors.

AWA PA1003 25W PA AMPLIFIER
AL4518 - modified

PHONO-RADIO TONE

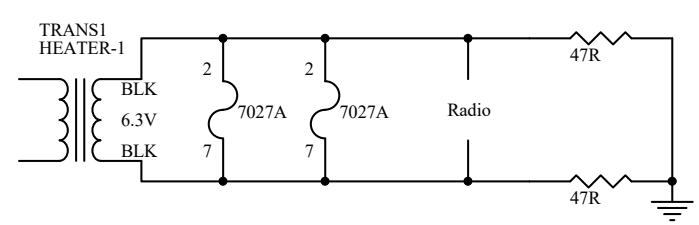
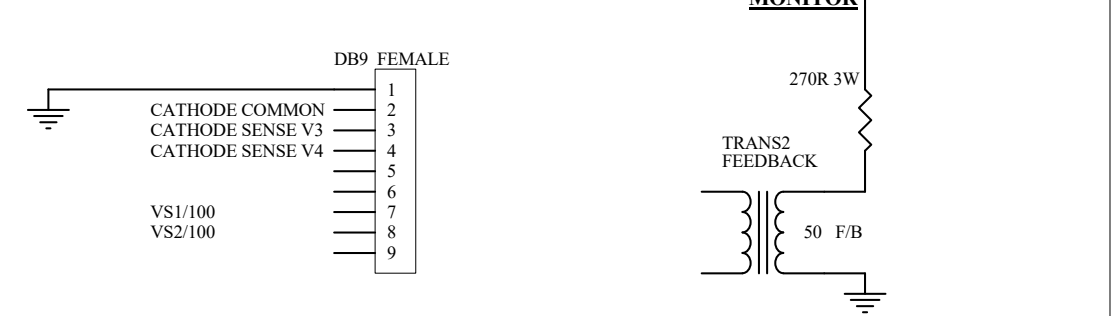
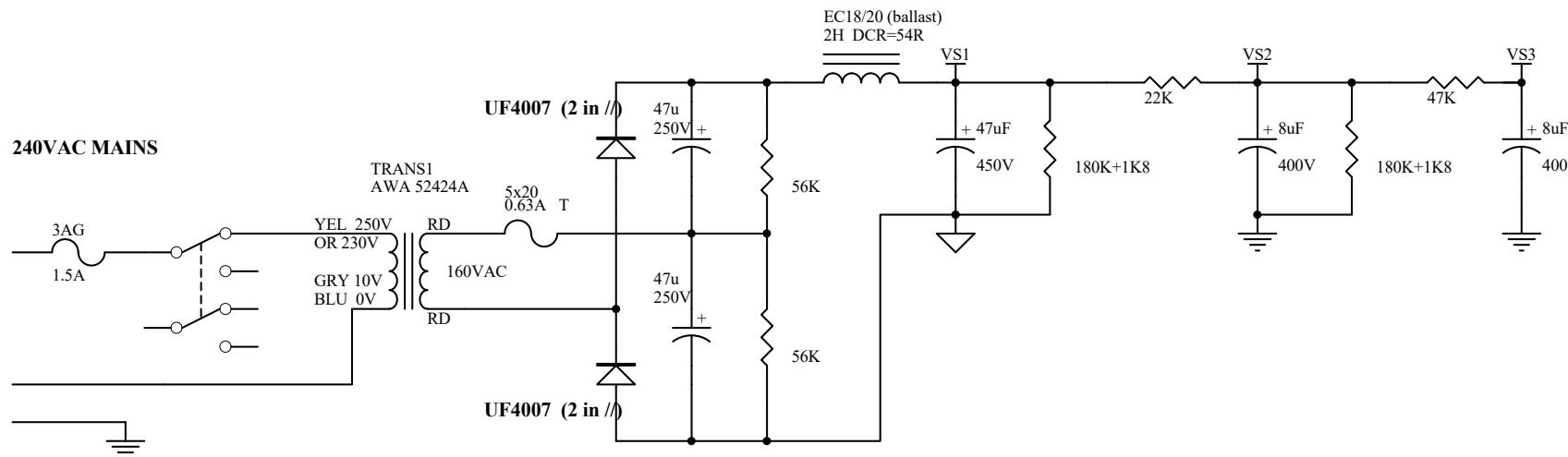
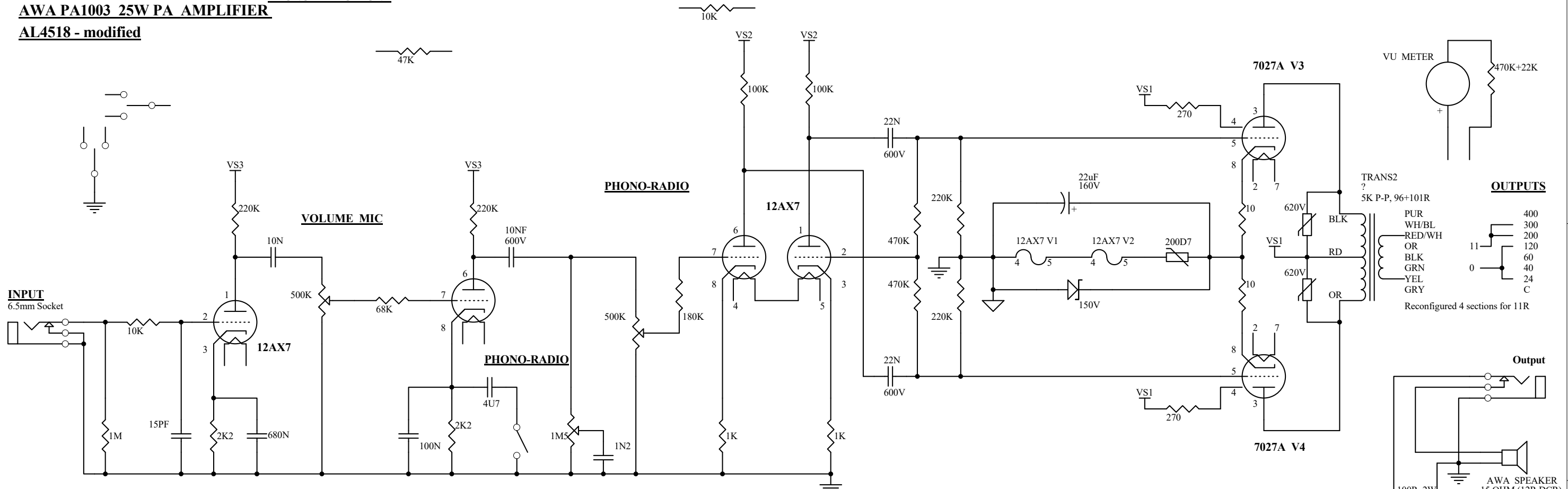

TRANS2	
PRI BLK	300 (BLK-WH)
PRI B+	60 (BLK)
PRI OR	200 (RD-WH)
PRI OR	24 (YEL)
FB -	40 (GRN)
	C (GRY)
	400 (PUR)

VOLTAGE RAILS	NO LOAD	VALVE	QTY
RAIL	V	12AX7	2
VS1	V	7027A	2
VS2	V		
VS3	V		

Title		
Size	Number	Revision
B		
Date:	22-Nov-2021	Sheet of
File:	C:\Program Files\Design Explorer 99 SE\Examples\Projects\Amplifier Modules.ddb	

AWA PA1003 25W PA AMPLIFIER
AL4518 - modified

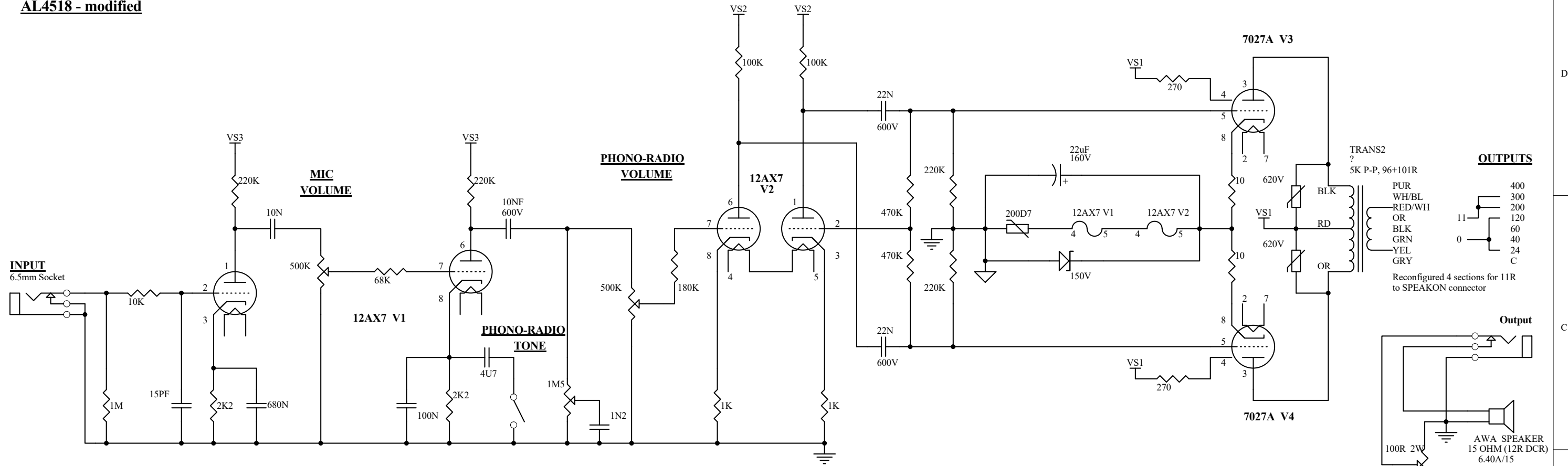

OUTPUTS

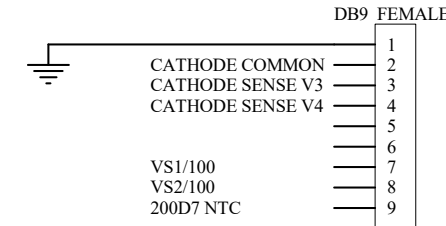
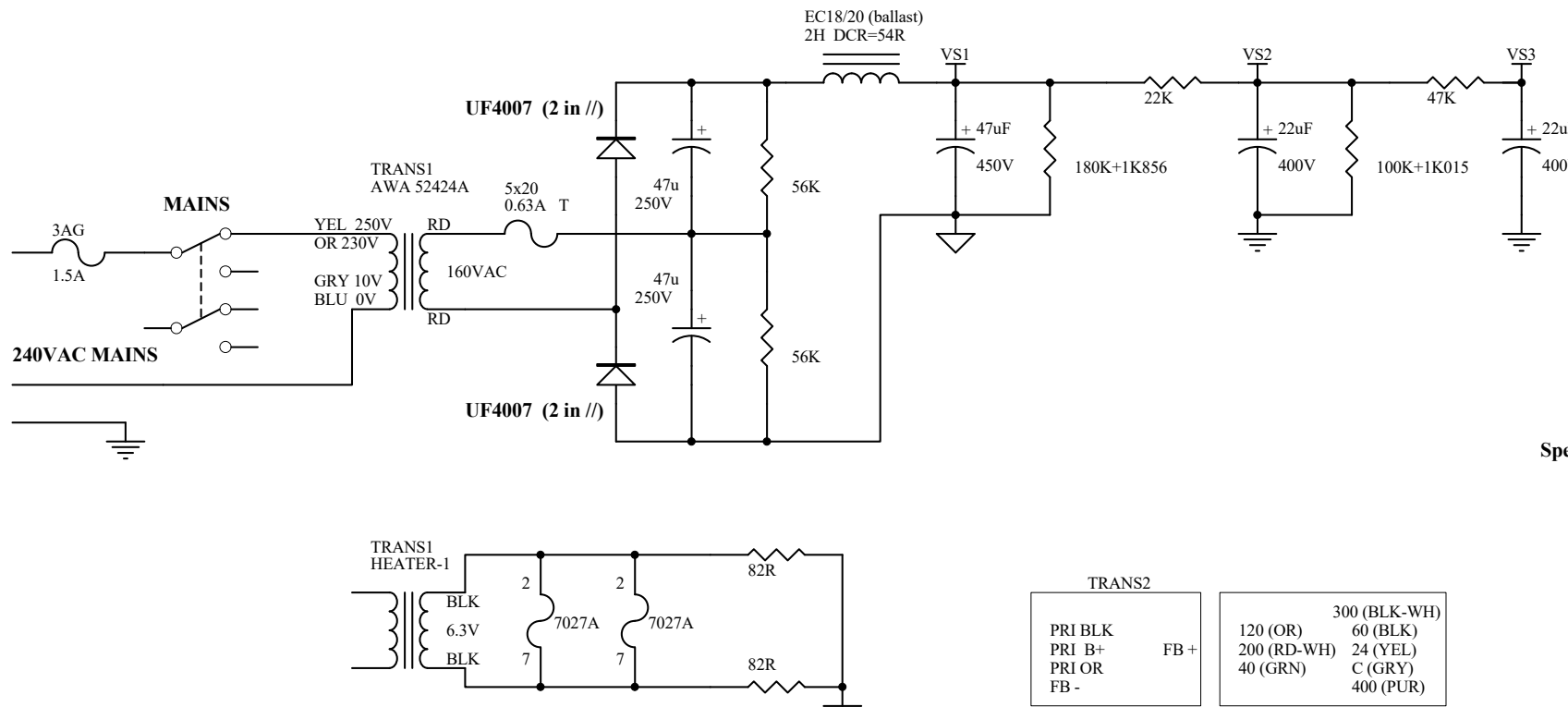
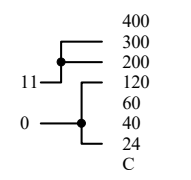

MONITOR

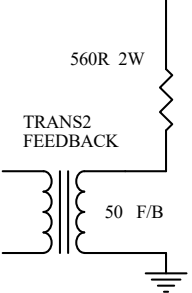

Speaker Output

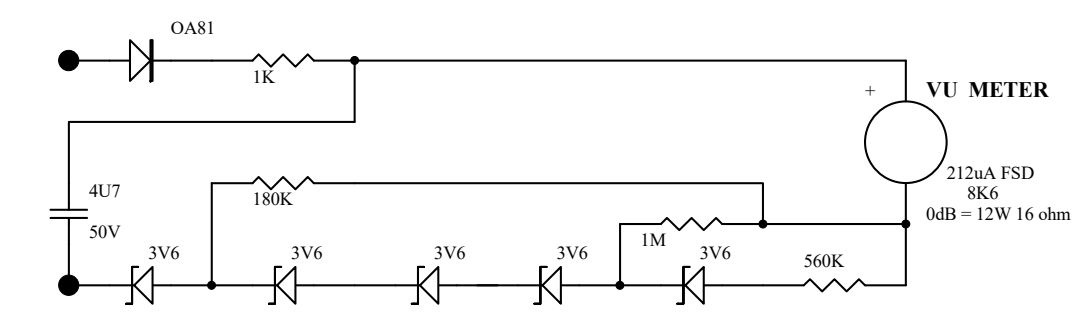

TRANS2	
PRI BLK	FB +
PRI B+	
PRI OR	
FB -	
	300 (BLK-WH)
	120 (OR)
	60 (BLK)
	200 (RD-WH)
	24 (YEL)
	40 (GRN)
	C (GRY)
	400 (PUR)

VOLTAGE RAILS	NO LOAD	VALVE	QTY
RAIL	380V	12AX7	2
VS1	255V	7027A	2
VS2	215V		
VS3	25V (70+70mA)		
Vcathode	25V		
NTC	4.4V		

Title		
Size	Number	Revision
B		
Date:	6-Dec-2021	Sheet of
File:	C:\Program Files\Design Explorer 99 SE\Examples\Projects\Amplifier Modules.ddb	